



ENVIRO 1A CART SPECIFICATIONS

ENVIRO 1A
PORTABLE CART NUMBER: 99-CR-0001-A

WATER SEPERATOR FILTER
ELEMENTS PART NUMBER: X99104D16

RETURN FILTER
ELEMENTS PART NUMBER: 47-WE51803AZ

ENVIRO 1A FILTER CART OPERATING INSTRUCTIONS

Before getting into the operation of the filter cart, certain descriptive terms need to be defined to ease the understanding of the instructions. They are:

SUCTION HOSE:

The suction hose draws fuel into the filter cart. It is attached to the smaller of the two filter housings (suction filter).

SUCTION FILTER:

The suction filter is the smaller of the two filter housing. It is equipped with two 100-mesh filter elements. Its function is to filter out large contaminants and to protect the pump from being damaged.

VACUUM GAUGE:

The vacuum gauge is located on the 90 degree elbow at the discharge side of the filter housing. It will tell the operator when to clean or replace the two 100 mesh filter elements in the suction filter housing.

RETURN HOSE:

The return hose discharges the clean fuel out of the filter cart. It is attached to the larger of the two filter housings (outlet filter).

OUTLET FILTER:

The outlet filter is the larger of the two filter housings. It contains two filter elements that do the final filtering of the fuel.

PRESSURE GAUGE:

The pressure gauge is located on the return filter housing. It will tell the operator when to replace the two filter elements.

RELIEF VALVE:

The relief valve is a safety feature on the filter cart. Its function is to divert fuel back to the suction filter in case the return filter elements are clogged or the return hose is plugged.

FILTER CART OPERATION

Operation of the **Enviro 1A** filter cart is fairly straightforward. Simply put both the suction and return hoses into the tank and turn the unit on.

To ensure that the fuel is filtered to a good degree of cleanliness, it is recommended that the total volume of fuel in the tank be exchanged (filtered) approximately two times. This will ensure that nearly all of the particles in the fuel, 5 microns or larger, have been removed.

The filter cart is equipped with a 6.5 G.P.M. pump/motor combination. Use the example and the formula below to calculate the time needed to clean the fuel in a tank.

Example:

Problem: Cleaning up a 500-gallon tank with a 6.5 G.P.M. filter cart

Solution:

Using the equation:

$$\frac{\text{Amount of Fuel to be Filtered (in Gallons)} \times 2}{\text{Rate of Filter Cart Pump (in G.P.M.)}} = \text{Time Required}$$

Therefore, by putting our values into this equation we find the following:

$$\frac{500 \text{ gallons}}{6.5 \text{ G.P.M.}} \times 2 = 154 \text{ minutes or } 2.57 \text{ hours}$$

Therefore we find that the filter cart should be run for 154 minutes in this situation.

Unless the fuel is severely contaminated and needs additional cleaning (sample to determine cleanliness of fuel.)

To further insure that all the fuel is filtered as equally as possible, it is suggested that the filter cart suction and return hoses be placed at opposite ends of the tank. It would also be advantageous to occasionally change the direction the hose ends are pointing.

After the filtering process has been completed, remove the suction hose from the tank while the filter cart is still running. This will force out most of the remaining fuel in the filter housings.

Caution! This process involves running the pump dry. Do not allow the pump to run dry for more than one minute. The fuel being pumped helps to lubricate and cool the gear pump. Damage to the pump may occur if it is allowed to run dry for more than one minute.

Drain cocks are provided at the bottom of both filter housings to drain any remaining fuel.

FILTER ELEMENT REPLACEMENT

Suction and return filter elements should be serviced when the vacuum or pressure gauges go into the red zones. The suction filter 100 mesh elements can be cleaned and reinstalled. The return line filter elements can not be cleaned and must be replaced. Reference the front cover of this booklet for the part number of the elements to be replaced.

It should be noted that the Enviro 1A Filter Cart is equipped with a 40 P.S.I. relief valve. Its function is to divert fuel back to the suction filter in case the outlet filter's elements have been clogged and need replacement. This also ensures that dirty, unfiltered fuel is never discharged out of the filter cart. It also serves as a safety feature to prevent hoses from blowing off if the return hose is kinked or plugged.

If any other questions concerning the operation or maintenance of the filter cart arise, contact the JCH Fuel Solutions Engineering Department.

Fuel Cleaning Systems Warranty

LIMITED WARRANTY

JCH Fuel Solutions makes every effort to assure that our products meet high quality and durability standards and we expressly warrant the products described herein which are manufactured by JCH Fuel Solutions against defects in Material and workmanship for a period of one (1) year from the date of purchase. This warranty is not intended to supplant normal inspection, care and service of the products covered hereby by the user, and shall not obligate JCH Fuel Solutions to provide free service during the warranty period to correct breakage, maladjustment or other difficulties arising out of abuse, misuse, or improper care and maintenance of such products. Our express warranty is subject to the following terms and conditions:

1. This warranty shall only extend to and is only for the benefit of original purchasers who use the products covered hereby for commercial or industrial purposes.
2. Any warranty claim received by JCH Fuel Solutions after one (1) year from the date of purchase will not be honored even if it is claimed that the defect occurred prior to one (1) year from the date of purchase.
3. This warranty shall not apply to products (1) which have been tampered with, altered or repaired by anyone other than JCH Fuel Solutions without the express prior written consent of JCH Fuel Solutions, (2) which have been installed improperly or subject to misuse, abuse, accident, negligence of others, improper operation or maintenance, neglect or modification, or (3) which have had the serial number altered, defaced or removed.
4. The liability of JCH Fuel Solutions under this warranty is limited to the repair or replacement of the defective product. JCH Fuel Solutions assumes NO LIABILITY for labor charges or other costs incurred by any purchaser incidental to the service, adjustment, repair, return, removal or replacement of products. JCH FUEL SOLUTIONS ASSUMES NO LIABILITY FOR ANY GENERAL, SPECIAL, INCIDENTAL, CONSEQUENTIAL, CONTINGENT OR OTHER DAMAGES UNDER ANY WARRANTY, EXPRESS OR IMPLIED, AND ALL SUCH LIABILITY IS HEREBY EXPRESSLY EXCLUDED.
5. JCH FUEL SOLUTIONS MAKES NO WARRANTIES, EXPRESS OR IMPLIED, OF MERCHANTABILITY, FITNESS FOR PARTICULAR PURPOSE OR OTHERWISE, WITH RESPECT TO THE PRODUCTS COVERED BY THIS WARRANTY POLICY, EXCEPT AS EXPRESSLY PROVIDED FOR HEREIN. NO EMPLOYEE, AGENT, REPRESENTATIVE OR DISTRIBUTOR IS AUTHORIZED TO MAKE ANY WARRANTY ON BEHALF OF JCH FUEL SOLUTIONS, OTHER THAN THE EXPRESS WARRANTY PROVIDED FOR HEREIN.
6. JCH Fuel Solutions reserves the right at any time to make changes in the design, material, function and specifications of its products. Any such changes shall not obligate JCH Fuel Solutions to make similar changes in such products that were previously manufactured.

WARRANTY CLAIM PROCEDURE

To make a claim under this warranty, please call our Customer Service Representative at **(888) 287-1627**. We will ask you to advise us of our Representative's name and address, the date of purchase, model number and a detailed explanation of the problem you are experiencing. The Customer Service Representative will arrange for a Field Engineer to inspect your system. If the inspection discloses a defect covered by our limited warranty, we will either repair or replace the defective parts or products at our election and at our cost. If upon inspection, our Engineer determines that there is no defect or that the damage to the system resulted from cases not within the scope of our limited warranty, then you must bear the cost of repair or replacement of the damaged parts. For service, please contact **JCH Fuel Solutions**.

JCH Fuel Solutions
4527 Losee Road
N. Las Vegas, NV 89031

Phone: (888) 287-1627 **Fax:** (702) 639-4101 **Direct:** (702) 639-4076

Internet: www.jchfuel.com **E-mail:** fuelsales@jchwire.com

ENVIRO 1A CART

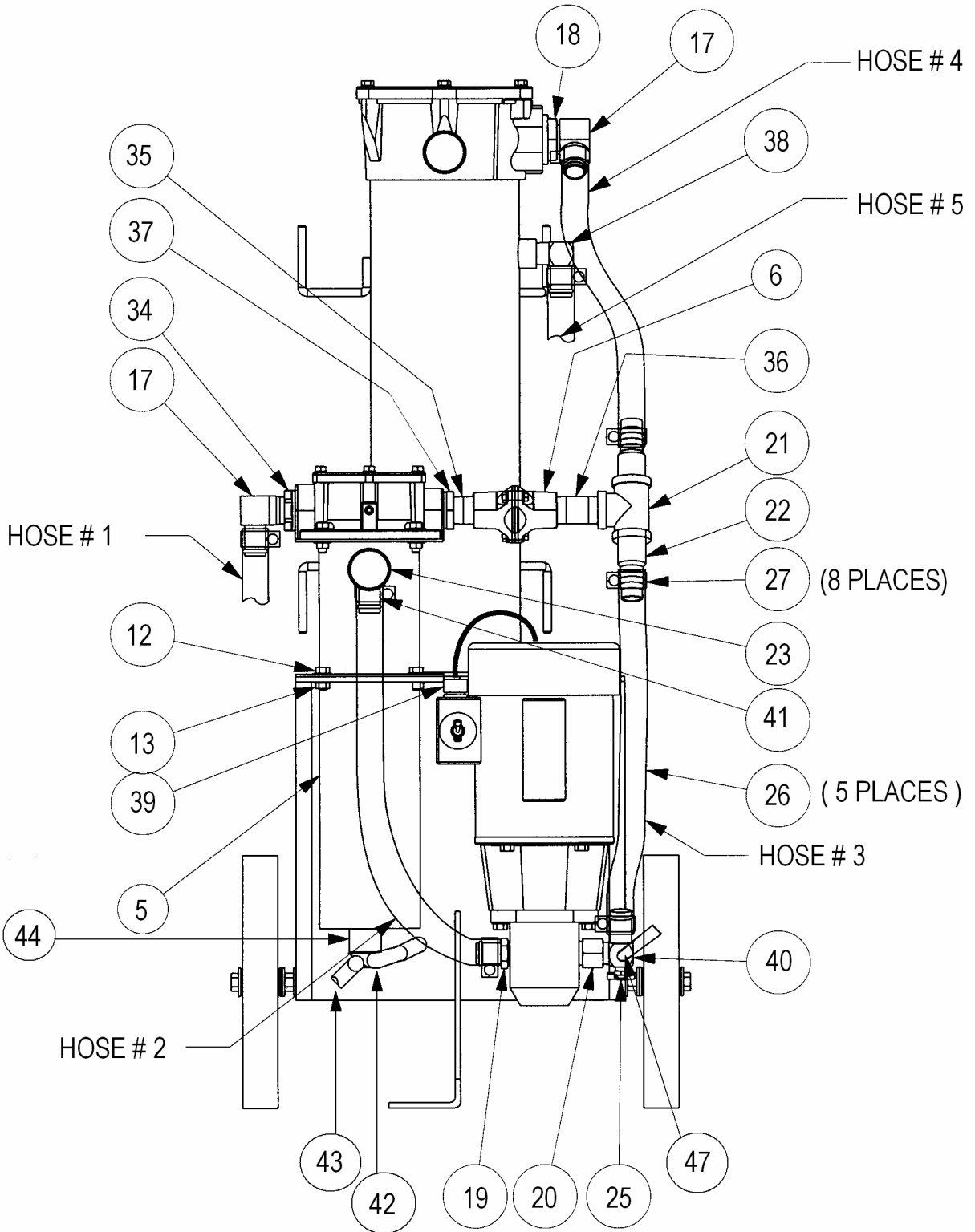

ENVIRO 1A CART

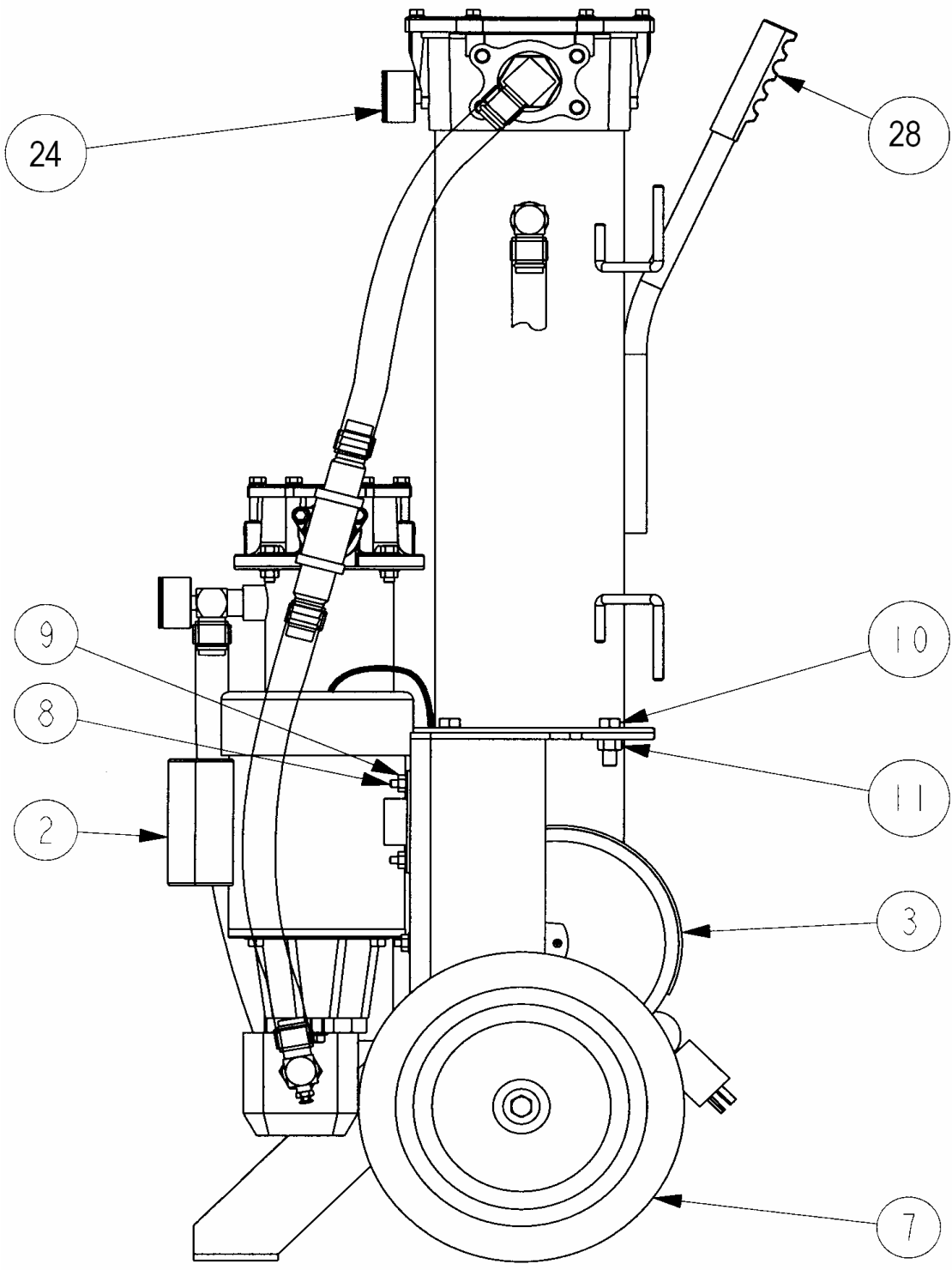

ENVIRO 1A CART

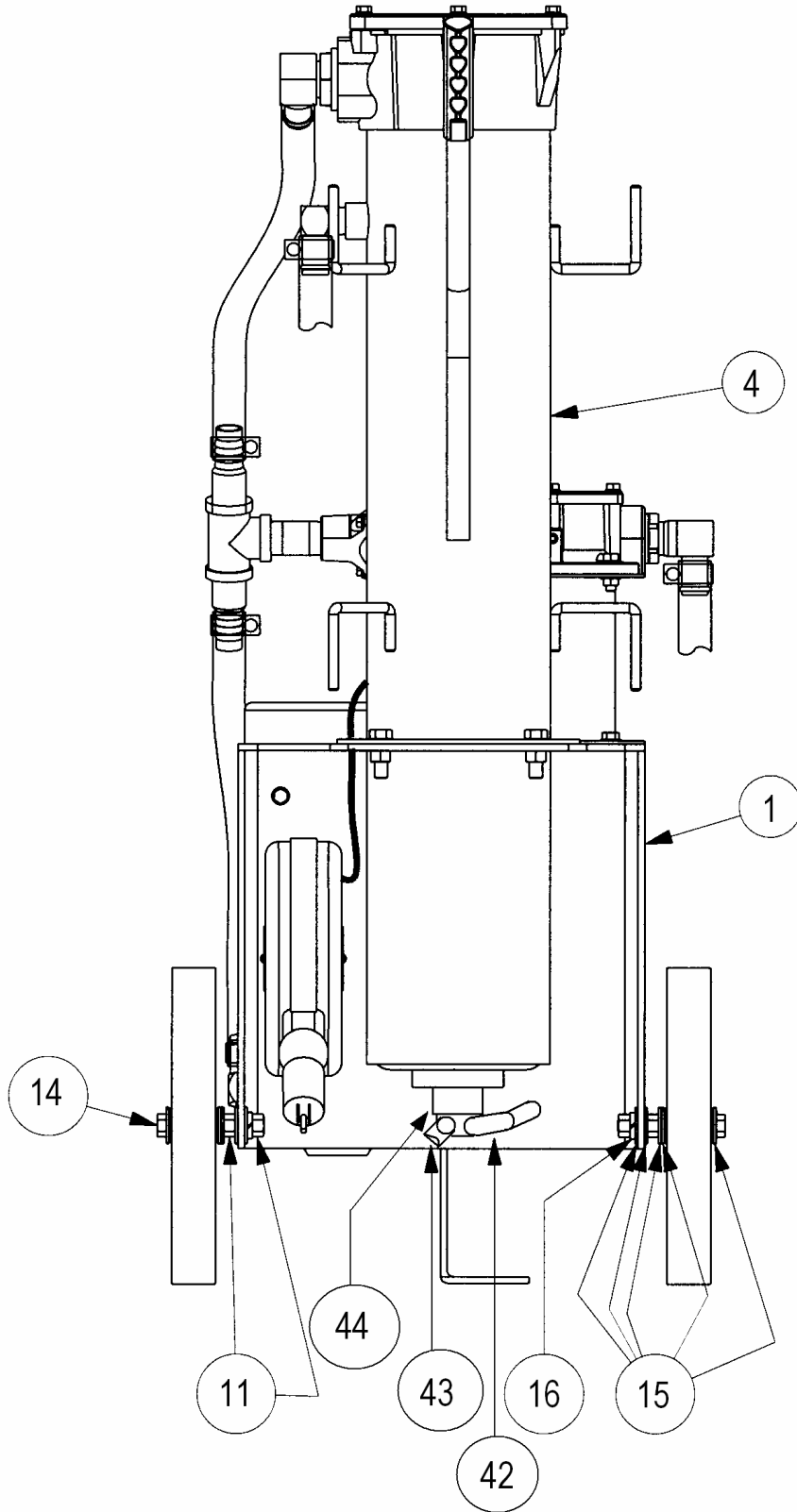

ENVIRO 1A CART

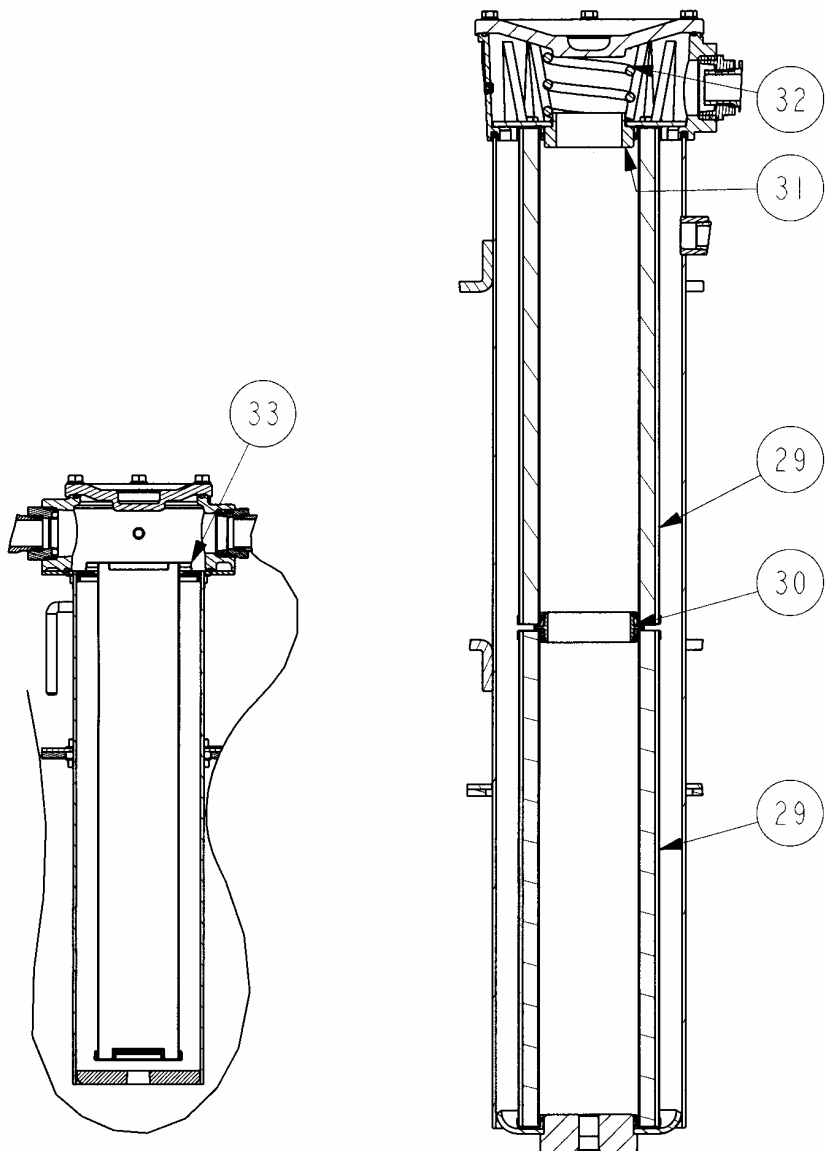

**RF STYLE INLET
FILTER DETAIL**

**WF2 STYLE OUTLET
FILTER DETAIL**

ENVIRO 1A FILTER CART

PARTS LIST

ITEM	QTY	ITEM NUMBER	DESCRIPTION
1	1	47-AA1189	FC601, FRAME ASSEMBLY, WHITE
2	1	47-AA1214	FC603, PUMP/MOTOR ASSEMBLY
3	1	47-AA1232	FC604, CORD REEL ASSEMBLY, WHITE
4	1	47-AB0633	X99104D07, SPECIAL WF2 STYLE FILTER ASSEMBLY, WHITE
5	1	47-AB0629	X99104D02, SPECIAL RF STYLE FILTER ASSEMBLY, WHITE
6	1	47-AA2034	LRV1040, CHECK VALVE, 40 PSID, 1" NPTF PORTS
7	2	47-AA1192	FC60010, FILTER CART WHEEL, WHITE
8	4	47-AA3211	PS0001, 5/16"-18 X 1" LONG SELF-LOCKING HEX BOLT
9	4	47-AA3259	PS1102, 5/16"-18 SELF-LOCKING HEX NUT
10	4	47-AA3220	PS0010, 1/2"-13 X 1 1/2" LONG HEX BOLT
11	8	47-AA3262	PS1105, 1/2"-13 HEX NUT
12	4	47-AA3212	PS0002, 3/8"-16 X 3/4" LONG SELF-LOCKING HEX BOLT
13	4	47-AA3257	PS1100, SELF-LOCKING NUT
14	2	47-AA9692	1/2"-13 X 3 3/4" LONG HEX BOLT
15	10	47-AA9041	1/2" I.D. FLAT WASHER, ZING PLATED
16	2	47-AA3247	PS1001, 1/2" I.D. SPLIT-RING LOCK WASHER
17	2	47-AA3351	PV101090, 90 DEG. ELBOW, 1" NPT TO 1" HOSE BEAD
18	1	47-AA3298	PS2766, REDUCER BUSHING, 2" NPT X 1" NPT
19	1	47-AA3362	PV1110, STRAIGHT FITTING SAE -17 TO 1" HOSE BEAD
20	1	47-AA1206	FC618, ADAPTER, SAE - 10 TO 3/4" NPT
21	1	47-AA3299	PS2767, TEE FITTING, 1" NPT, BLACK PIPE
22	2	47-AA1316	FT100ZP, 1" NPT TO 1" HOSE BARB
23	1	47-AA1482	GV10, VACUUM GAUGE, COLOR INDICATING FACE
24	1	47-AA0749	CI20, PRESSURE GAUGE, COLOR INDICATING FACE
25	1	47-AA1205	FC60016, DRAINCOCK, 1/4" NPT
26	(25 FT)	47-AA1230	FC60007, 1" I.D. HOSE
27	8	47-AA1557	HC075, HOSE CLAMP
28	1	47-AA1215	FC60030, PLASTIC HANDLE GRIP
29	2	47-AA6340	WE51803AZ, 3 MICRON AQUA-ZORB™ ELEMENTS
30	1	47-AA6403	WF08, WF2 FILTER ELEMENT CONNECTOR
31	1	47-AB0635	X99104D09, SUBPLATE ASSEMBLY
32	1	47-AA3930	RS02, WF2 FILTER ELEMENT HOLD-DOWN SPRING
33	1	47-AB0669	X99104D16, FILTER BASKET
34	1	47-AA5694	TF101501, REDUCER BUSHING, 1 1/2" NPTF TO 1" NPTF
35	1	47-AA3295	PS2763, 1" NPT X 2" LONG PIPE NIPPLE
36	1	47-AA3301	PS2769, 1" NPT X 3" LONG PIPE NIPPLE
37	1	47-AA3296	PS2764, REDUCER BUSHING, 1 1/4" NPT X 1" NPT
38	1	47-AA3331	PV071090, 90 DEG. ELBOW, 3/4" NPT X 1" HOSE BEAD
39	1	47-AA1202	FC60313, CORD STRAIN RELIEF
40	1	47-AB0640	X99104D14, 90 DEG. ELBOW, 3/4" NPT X 1" HOSE W/ 1/4" NPT PORT
41	1	47-AB0645	X99104D15, 90 DEG. ELBOW, 3/4" NPT X 1" HOSE W/ 1/8" NPT PORT

ENVIRO 1A OUTLET FILTER SUBASSEMBLY

PARTS LIST

ITEM	QTY	ITEM NUMBER	DESCRIPTION
1	6	47-AA3211	PS0001, 5/16"-18 X 1" LONG SELF-LOCKING BOLT
2	1	47-AA6400	WF06, TOP COVER, NO OIL FILL PORT
3	1	47-AA3898	RG05, COVER SEAL, BUNA "N"
4	1	47-AA6831	WF252002, PORT BODY, 2 1/2" 4-BOLT FLANGE & 2" NPTF
5	1	47-AA3271	PS1600, 1/8" NPT PIPE PLUG W/ SEALANT
6	4	47-AA3223	PS0013, 3/8"-16 X 1 1/4" LONG NYLON INSERT BOLT
7	4	47-AA3248	PS1002, FLAT WASHER
8	1	47-AA3899	RG06, HOUSING SEAL, BUNA "N"
9	1	47-AB0639	X99104D13, SPECIAL BOTTOM HOUSING, WHITE

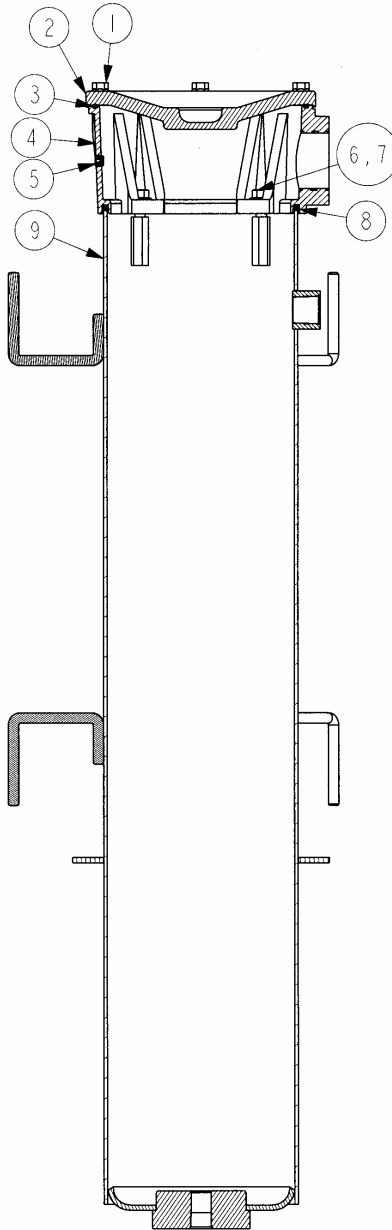

ENVIRO 1A PUMP/MOTOR SUBASSEMBLY

PARTS LIST

ITEM	QTY	ITEM NUMBER	DESCRIPTION
A	1	47-AA1219	FC63A, ELEC. MOTOR; 1725 R.P.M.; ¾ H.P.; TEFC; 115 V.A.C.; W/ FOOT
B	1	47-AA1220	FC63B, GEAR PUMP; 0.87IN ³ DISPLACEMENT; 6.6 G.P.M. @ 1725 R.P.M.
C	2	47-AA1221	FC63C, COUPLING BODY
D	1	47-AA1222	FC63D, COUPLING SPIDER
F	1	47-AA0117	FC63F, C-FACE MOTOR/PUMP ADAPTER
G	1	47-AA1202	FC63G, STRAIN RELIEF CONNECTOR CORD GRIP; LIQUID TIGHT
H	1	47-AA1225	FC63H, TOGGLE SWITCH; SINGLE POLE / SINGLE THROW
J	2	47-AA6180	VD06, VALVE DISK
K	4	47-AA3212	PS0002, 3/8"-16 X 3/4" LG. SELF LOCKING BOLT
L	2	47-AA3254	PS1008, 3/8" SPLIT-RING LOCK WASHER
M	2	47-AA3223	PS0013, 3/8"-16 X 1 ¼" LONG NYLON INSERT BOLT

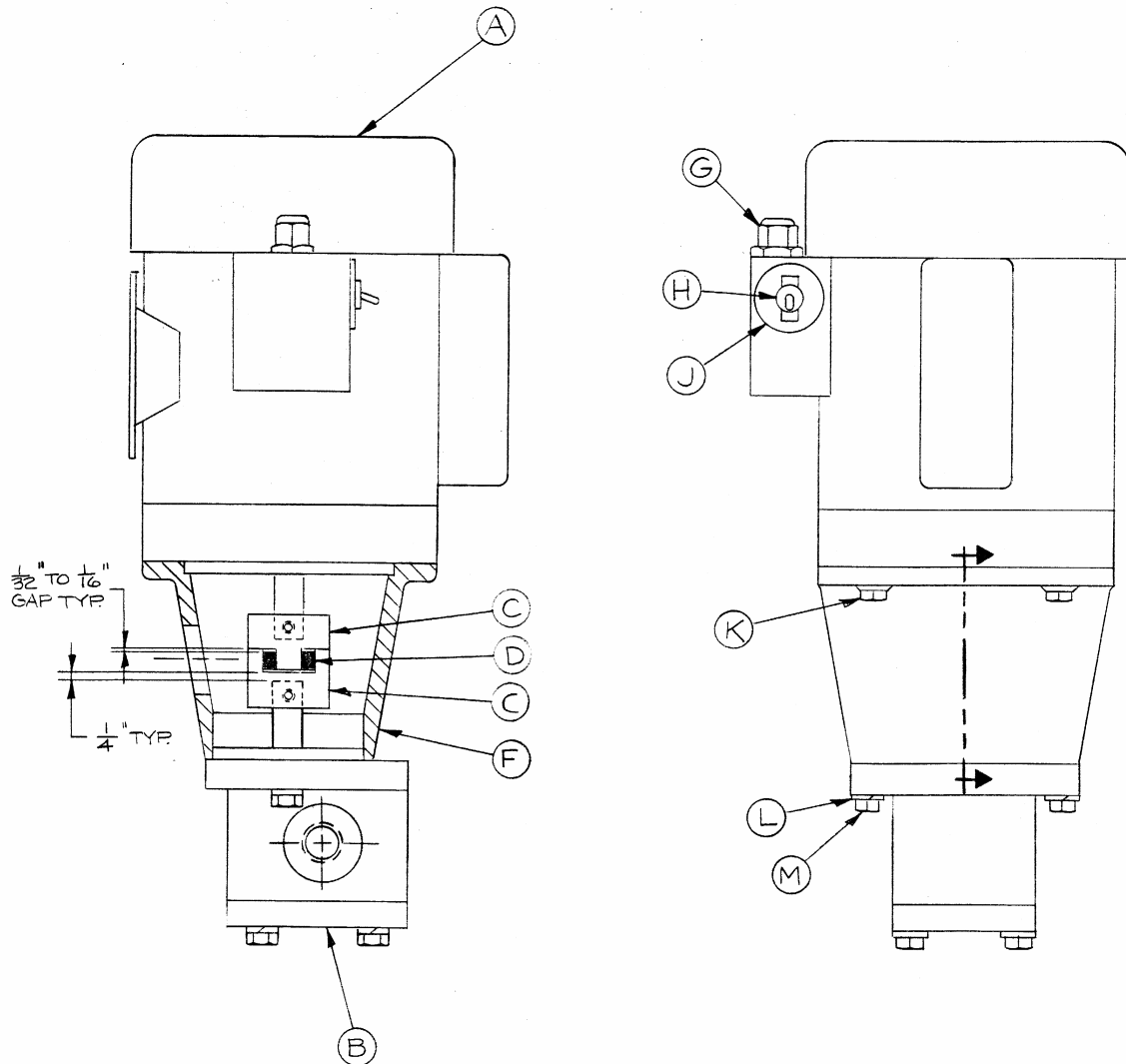

ENVIRO 1A INLET FILTER SUBASSEMBLY

PARTS LIST

ITEM	QTY	ITEM NUMBER	DESCRIPTION
1	6	47-AA3211	PS0001, 5/16"-18 X 1" LONG SELF-LOCKING BOLT
2	1	47-AA3554	RF03, TOP COVER, NO OIL FILL PORT
3	1	47-AA3891	RG02, COVER SEAL, BUNA "N"
4	1	47-AA3557	RF1215, PORT BODY, 1 1/4" NPTF & 1 1/2" NPTF PORTS
5	4	47-AA3223	PS0013, 3/8"-16 X 1 1/4" LONG NYLON INSERT BOLT
6	4	47-AA3248	PS1002, FLAT WASHER
7	2	47-AA3271	PS1600, 1/8" NPT PIPE PLUG W/ SEALANT
8	1	47-AA3893	RG03, HOUSING SEAL, BUNA "N"
9	1	47-AB0638	X99104D12, SPECIAL BOTTOM HOUSING, WHITE
10	4	47-AA3257	PS1110, 3/8"-16 NYLON LOCK NUT

